



- Guard Booth Pictured Sold Separately

RIZON

PEGASUS GB-VA

Guard Booth Vehicle Access Platform

Common Applications

- Security Checkpoints
- Property Protection
- Employee and Visitor Access Control
- Ticket Booths
- Property Surveillance

Enhance vehicle access control at your site with the Rizon Pegasus GB-VA Vehicle Gate Arm Accessory. Built as a dedicated add-on for the Pegasus GB, the GB-VA comes standard with two Rizon BAVG vehicle gates, providing reliable traffic control right out of the box. Multiple gate arm length options are available to accommodate a wide range of lane widths and site layouts. Each gate arm is equipped with color-changing red and green LEDs, ensuring clear visual guidance for drivers in all lighting conditions. For flexible credential presentation, the GB-VA includes card reader goosenecks at both car height and semi-truck height, making it ideal for mixed vehicle environments such as logistics centers, industrial facilities, and secured campuses. While the system works best when paired with Rizon Ultimate Readers for optimal performance and integration, it is also fully compatible with any access control system, giving you the freedom to use your preferred credentials and infrastructure.

TECHNICAL SPECIFICATIONS and POWER REQUIREMENTS

1. PAINTED INTERIOR AND EXTERIOR WITH (QD) QUICK DRYING ENAMEL PAINT SPECIALLY FORMULATED FOR INDUSTRIAL APPLICATIONS. STANDARD COLOR TO BE RAL 2008 ORANGE (CUSTOM COLORS AVAILABLE UPON REQUEST - LEAD TIMES MAY VARY)
2. POWER CORD WITH THREE BLADE MALE CONNECTION PLUG SUPPLYING 240/120 VOLTS.
3. MINIMUM AMPERAGE REQUIREMENTS - 20 AMPS (WITHOUT GUARD BOOTH) 50 AMPS (WITH GUARD BOOTH).

PEGASUS GB-VA DIMENSIONS (WITHOUT GB)

Overall Weight: 3,734 LBS

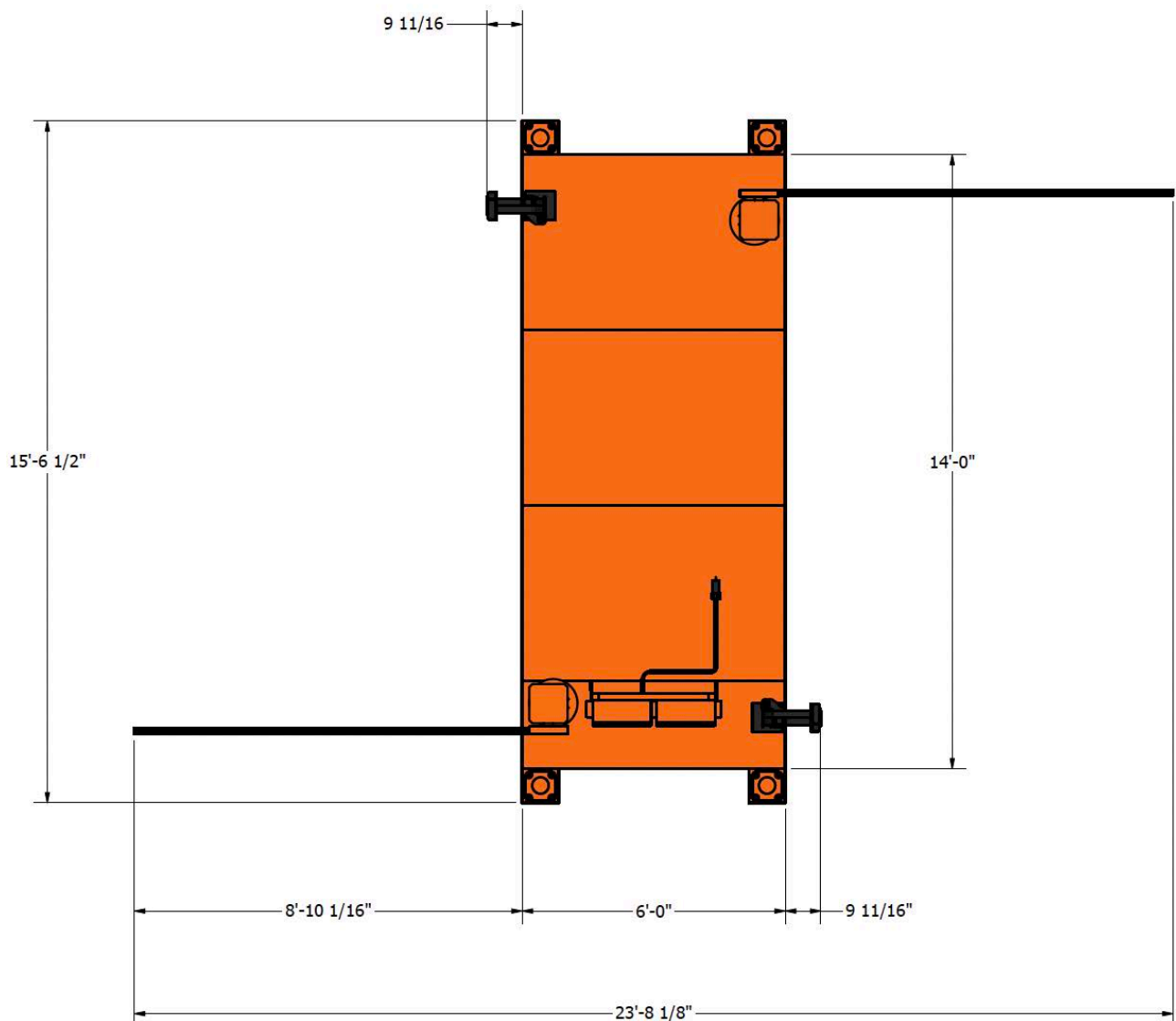

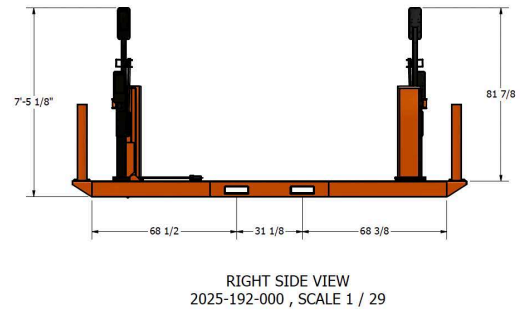
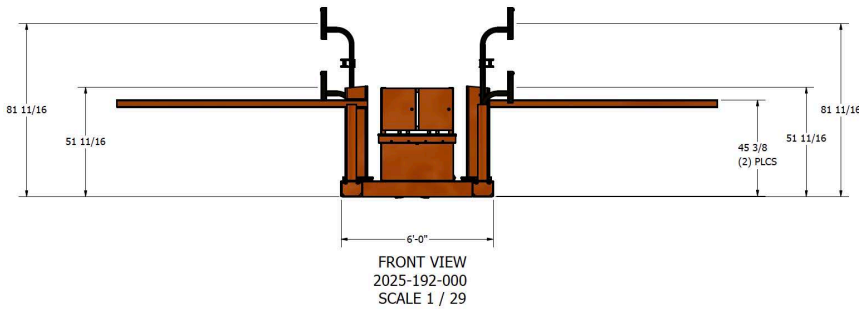

PEGASUS GB-VA DIMENSIONS (WITH GB)

Overall Weight: 6,300 LBS

